

# SJE Rhombus®

## Pump Switch Installation Instructions

SJE-Rhombus® wide angle pump switches are designed to provide automatic control of pumps in non-potable water and sewage applications. The SJE PumpMaster®, SJE PumpMaster® Plus and SJE PumpMaster® SPDT pump switches passed NSF Standard 61 protocol by an approved Water Quality Association laboratory for use in potable water applications.

### SJE PUMPMASTER®



Mechanically activated pump switch for direct control of pumps in:

- Sewage
- Non-potable Water
- Potable Water

U.S. Patent Nos. 5,087,801 & 5,142,108

tether length	<b>3.5</b>	<b>6</b>	<b>10</b>	<b>14</b>	<b>18</b>	<b>22</b>	<b>24</b>
	<small>min.</small>						
pumping range	<b>7</b>	<b>10</b>	<b>16</b>	<b>22</b>	<b>28</b>	<b>33</b>	<b>36</b>

### SJE PUMPMASTER® PLUS



Mechanically activated pump switch for direct control of pumps in:

- Sewage
- Non-potable Water
- Potable Water

U.S. Patent Nos. 5,087,801 & 5,142,108

tether length	<b>3.5</b>	<b>6</b>	<b>10</b>	<b>14</b>	<b>18</b>	<b>22</b>	<b>24</b>
	<small>min.</small>						
pumping range	<b>7</b>	<b>10</b>	<b>16</b>	<b>22</b>	<b>28</b>	<b>33</b>	<b>36</b>

### SJE PUMPMASTER® SPDT



Mechanically activated pump switch for direct control of pumps in:

- Sewage
- Non-potable Water
- Potable Water

U.S. Patent Nos. 5,087,801 & 5,142,108

tether length	<b>3.5</b>	<b>6</b>	<b>10</b>	<b>14</b>	<b>18</b>	<b>22</b>	<b>24</b>
	<small>min.</small>						
pumping range	<b>7</b>	<b>10</b>	<b>16</b>	<b>22</b>	<b>28</b>	<b>33</b>	<b>36</b>

### JUNIOR SUPER SINGLE®



Mechanically activated pump switch for direct control of pumps in:

- Sewage
- Non-potable Water
- Non-turbulent applications

U.S. Patent Nos. 4,429,854 & 4,572,934

tether length	<b>3.5</b>	<b>6</b>	<b>8</b>	<b>10</b>	<b>12</b>	<b>15</b>	<b>17</b>
	<small>min.</small>						
pumping range	<b>6.5</b>	<b>8.5</b>	<b>11</b>	<b>13</b>	<b>14</b>	<b>17</b>	<b>19</b>

### SUPER SINGLE®



Mechanically activated pump switch for direct control of pumps in:

- Sewage
- Non-potable Water

U.S. Patent Nos. 4,302,641

tether length	<b>3.5</b>	<b>5</b>	<b>7</b>	<b>9</b>	<b>13</b>	<b>15</b>
	<small>min.</small>					
pumping range	<b>7</b>	<b>7.5</b>	<b>8.5</b>	<b>11</b>	<b>12.5</b>	<b>13.5</b>

### SJE AMPMASTER®



Mechanically activated pump switch for direct control of pumps in:

- Sewage
- Non-potable Water

U.S. Patent Nos. 5,087,801 & 5,142,108

tether length	<b>5</b>	<b>10</b>	<b>14</b>	<b>18</b>	<b>22</b>
	<small>min.</small>				<small>max.</small>
pumping range	<b>9</b>	<b>13</b>	<b>17</b>	<b>21</b>	<b>24</b>

### PREVENTATIVE MAINTENANCE

- Periodically inspect the product. Check that the cable has not become worn or that the housing has not been damaged so as to impair the protection of the product. Replace the product immediately if any damage is found or suspected.
- Periodically check to see that the float is free to move and operate the switch.
- Use only SJE Rhombus® replacement parts.
- The Junior Super Single® and Super Single® pump switches contain mercury and MUST be recycled or disposed of according to local, state and federal codes.

	<p><b>⚠ WARNING ELECTRICAL SHOCK HAZARD</b>                  Disconnect power before installing or servicing this product. A qualified service person must install and service this product according to applicable electrical and plumbing codes.</p>		<p><b>⚠ WARNING EXPLOSION OR FIRE HAZARD</b>                  Do not use this product with flammable liquids. Do not install in hazardous locations as defined by National Electrical Code, ANSI/NFPA 70.</p>
--	--	--	---

Failure to follow these precautions could result in serious injury or death. Replace product immediately if switch cable becomes damaged or severed. Keep these instructions with warranty after installation. This product must be installed in accordance with National Electric Code, ANSI/NFPA 70 so as to prevent moisture from entering or accumulating within boxes, conduit bodies, fittings, float housing, or cable.

**MOUNTING THE SWITCH**

1. Determine the required cord tether length according to product specifications on the front page and as shown in Figure A.
2. Place the cord into the clamp as shown in Figure B.
3. Locate clamp at designed activation level and secure the clamp to the discharge pipe as shown in Figure B. Note: Do not install cord under the hose clamp.
4. Tighten the hose clamp using a screwdriver. Over tightening may result in damage to the plastic clamp. Make sure the float cable is not allowed to touch the excess hose clamp band during operation.
5. Follow direct wire or piggy-back instructions for further installation.

**PIGGY-BACK PLUG INSTALL**

- Electrical outlet must not be located in pump chamber.
  - Electrical outlet voltage, piggy-back plug voltage, and pump voltage must match.
1. Follow steps 1 through 4 of "Mounting The Switch".
  2. Insert switch's piggy-back plug into outlet.
  3. Plug pump into piggy-back plug as shown in Figure A.
  4. Check installation. Allow system to cycle to insure proper operation.

**DIRECT WIRE INSTALL**

1. Follow steps 1 through 4 of "Mounting The Switch".
2. Wire switch as shown below.
3. Check installation. Allow system to cycle to insure proper operation.

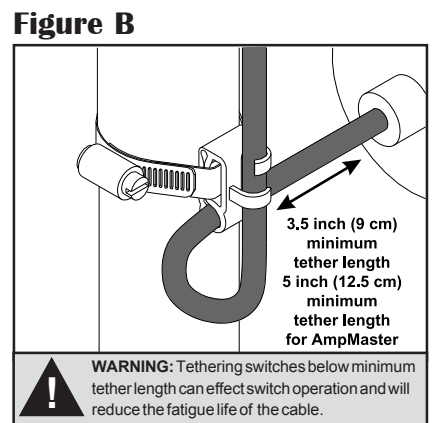

**Note:** All hose clamp components are made of 18-8 stainless steel material. See your SJE Rhombus® supplier for replacements.

**Figure A**

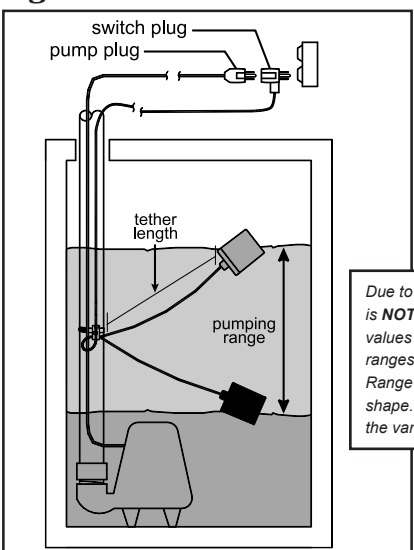

Due to weight of cable, pumping range above horizontal is **NOT** equal to pumping range below horizontal. Use values published on front page as a guide. Pumping ranges are based on testing in non-turbulent conditions. Range may vary due to water temperature and cord shape. **Note:** As the tether length increases, so does the variance of the pumping range.

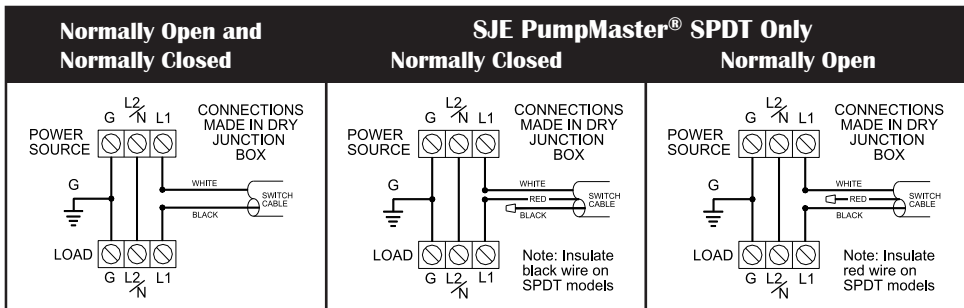

**⚠ WARNING**

In 230 VAC installations, one side of the line going to the load is always **HOT**. This condition exists if the switch is on or off. Install double pole disconnect on all 230 VAC circuits.

On SPDT Models, insulate unused red or black wires with wire nut. Wire can become electrically hot.

Ensure cable connections are performed in a **dry** junction box or other watertight seal that seals both conductors and cable jacket. Failure to do so could result in electrical shock hazard and/or water traveling down cable and entering the switch. Failure to guard against this may affect switch performance.